

# Hand Chain Hoist

**Capacity: 250kg**

**FEATURES**

- Lightweight robust construction
- Chrome plated covers
- Super strength alloy loadchain
- Minimum headroom
- Thrust race in lower hook
- Fully enclosed gear train
- Galvanised hand and loadchain
- Minimum effort to lift W.L.L.
- Spare parts always available

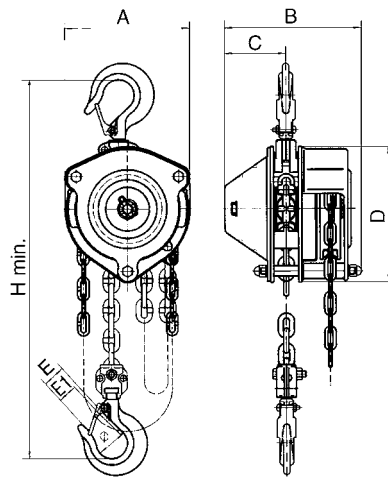

<b>Model</b>		CBOZ002-2
W.L.L.	tonnes	0.25
Lift	m	2
Test load	t	0.375
Headroom (hook to hook)	H min.	mm 230
Effort to lift full load	N	kg 12
No. of load chain fall lines		1
Load chain (dia. x pitch)	mm	ø4 x 12
<b>Dimensions</b>		A
		B
		C
	mm	D
		E
		E1
	ø	25
Net weight	kg	3.5
Extra weight per metre of extra lift	kg	0.54

**COMPLIES WITH AS/NZS1418.2**

Meets or exceeds all relevant world standards