

DUAL SPEED ELECTRIC CHAIN HOIST



HOISTING
EQUIPMENT
SPECIALISTS
Quality Lifting and Rigging Solutions

OrBlok
HOISTS

www.hesgroup.com.au 1300 792 464

DUAL SPEED ELECTRIC CHAIN HOIST

This economical and robust dual speed electric chain hoist is ideal for hoisting heavy objects in a wide range of applications, providing safety and efficiency in the workplace.

FEATURES

- 2 speed constant torque inverter motor with overload protection
- All aluminium alloy die cast hoist body, IP54
- Gearbox with fully machined helical gears, case hardened, oil bath lubrication
- Inverter control board with five fold protection against undervoltage, overvoltage, overheat, overload and overcurrent
- Lightweight, ergonomically designed handheld pendant made in Italy, IP65
- Durable and wear resistant RUD load chain
- Corrosive resistant, long lasting alloy steel chain sprocket
- Consistent, German made limit switches for flawless functionality
- Weipu aviation plugs and sockets for constant conductivity, and elimination of plug falling off
- Heavy duty chain bucket, protects and reduces wear and tear on the chain.
- Optional top hanger



HANGER SUSPENSION OPTIONAL

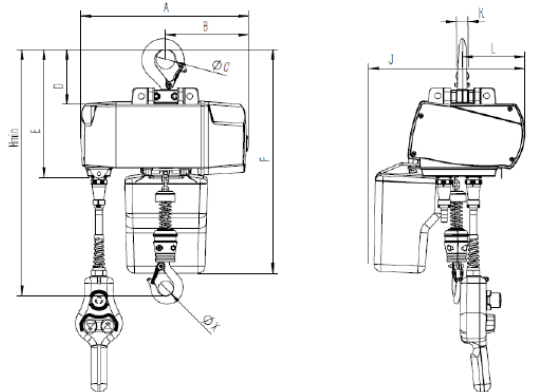

DIMENSIONS

Product Code	Working Load Limit WLL	A	B	C	D	E	F	Hmin	J	L	K	X
ECHOZH002-1P	0.25t	345	170	24	102	233	450	382	320	13	116	24
ECHOZH005-1P	0.5t	345	170	27	113	244	461	424	320	16	116	27
ECHOZH010-3P	1.0t	458	204	35	127	313	578	569	427	22	117	35

SPECIFICATIONS

Product Code	Working Load Limit WLL	Lifting Height (M)	Working Level (ISO)	Dual Speed (M /Min)	Load Chain (mm)	Falls of Chain	Voltage (V/Hz)	Duty Cycle (FC%)	Net Weight (kg)
ECHOZH002-1P	0.25t	3 - 6	M5	5/20	4X12	1	240	40	22
ECHOZH005-1P	0.5t	3 - 6	M5	1.5/6	5X15	1	240	40	23
ECHOZH010-3P	1.0t	3 - 6	M5	2/8	7X21	1	415	40	48