

# Lever Hoists

**Capacities: 800kg to 9 tonnes**

**FEATURES**

- Robust all steel construction
- Simple Free-wheel operation
- Super strength alloy load chain  
1.6t, 3t, 6t and 9t models fitted with Grade 100 chain
- Powder coated paint finish
- Stainless steel name plates
- Cast steel safety latches
- Four pocket lift wheel
- Forged malleable hooks with wide throat opening and deformation indicators
- Test certificate and instruction manual supplied with every hoist
- Spare parts always available

**IMPORTANT FEATURE**

- Minimal pre-load required to activate brake

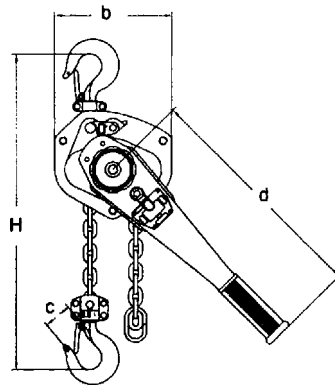

0.80, 1.6 & 3 tonne

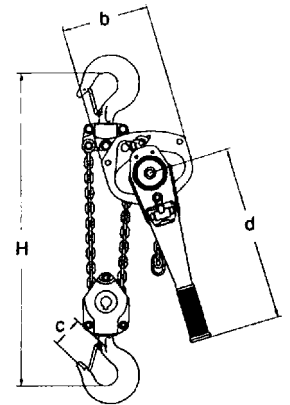
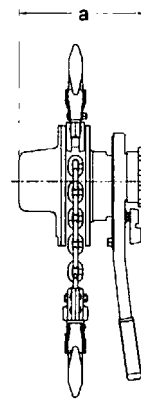

6 tonne

Capacity (tonnes)	Model No.	No. of Falls	Chain dia. (mm)	Load Chain Grade	Effort to Lift Rated Load (kg)	Net Wt. with 1.5m Lift (kg)	Extra Wt. per m (kg)	Dimensions (mm)				
								a	b	c	d	H
0.80	LHOZM008	1	6.3	80	15	6.9	0.85	148	128	37	256	295
1.6	LHOZM016	1	7.1	100	18	9.7	1.11	163	148	47	368	335
3	LHOZM030	1	9.0	100	38	16.3	1.77	191	181	62	368	405
6	LHOZM060	2	9.0	100	39	26.7	3.55	191	244	78	368	550
9	LHOZM090	3	9.0	100	43	38.5	5.32	191	314	X	368	680

**COMPLIES WITH AS/NZS1418.2**

Meets or exceeds all relevant world standards