

# G80 SWIVEL BALL BEARING HOOK

## SPECIFICATION FOR 8MM TO 16MM



### G80 Swivel Ball Bearing Hook with Safety Catch

Austlift Grade 80 swivel sling hooks are designed with a ball bearing swivel to allow the hook to swivel thus reducing the twist of a sling. Comes with heavy duty safety latch.

- Marked with chain size, designation, grade, manufacture quality mark and Austlift branded.
- Batch tested, test certificates available upon request.
- Spare trigger kits are available.
- Fatigue tested > 20,000 times.



### Application

- Building construction sites
- Ship building yards
- Crane production sites
- Mine production sites
- Engineering Workshops

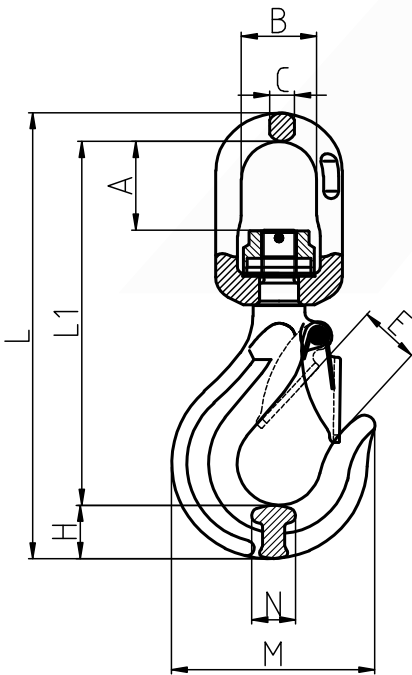

SIZE (mm)	CODE	WLL (T)	Wt. (kg)	DIMENSIONS (mm)								
				A	B	E	M	LI	L	N	C	H
8	103308	2	0.95	42	36	28.5	88	170	208	20	13	23
10	103310	3.15	1.71	50	42	31	105	204.8	251.7	23	15.5	29.5
13	103313	5.3	2.97	58	50	43.7	135	242	303.6	32	17	38
16	103316	8	5.3	63.5	61	45	161	291.8	360.8	37.5	21.5	45.4

AUSTLIFT Lifting your business to a higher level.

**NSW Head Office**

43 Frank Street  
 Wetherill Park, NSW 2164  
 02 9757 2277

**WA Office**

42 Mulgal Road  
 Malaga, WA 6090  
 08 9248 6674

**QLD Office**

7 Durbell Street  
 Acacia Ridge, QLD 4110  
 07 3272 0777

**VIC Office**

475 Dohertys Road  
 Truganina, VIC 3029  
 03 9314 5525