

TOGGLE TYPE PIPE LIFTER

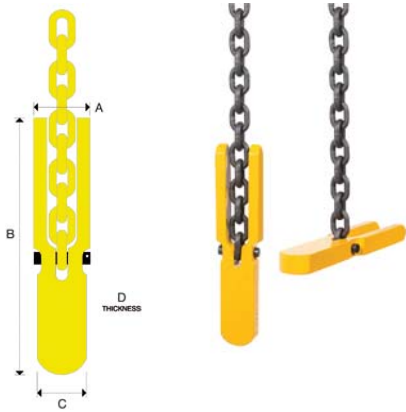

Code	WLL Tonnes	Dimensions in mm				Weight kg
		A	B	C	D	
CONPL2T	2	58	365	46	25	1.5 (no chain)

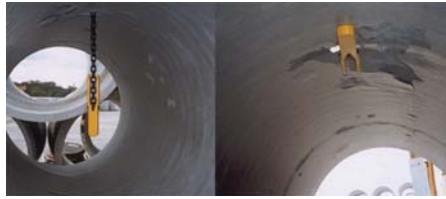

- Suits 8mm Grade 80 chain, length to order (not included).

SPADE TYPE PIPE LIFTER

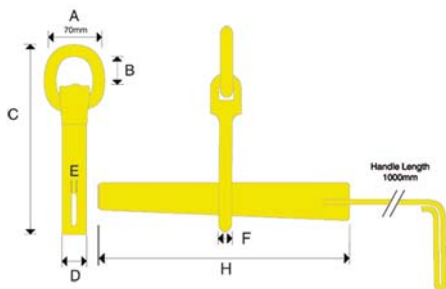

Code	WLL Tonnes	Dimensions in mm							Weight kg
		A	B	C	D	E	F	H	
CONPL5T	5	70	70	405	65	9	26	500	7.4
CONPL8T	8	75	70	525	70	12	28	700	13.5



PIPE LIFTING HOOKS

- For use with steel or cast pipes
- Included Sling Angle to be within 60° to 90°

COMPLIES WITH AS 4991-2004

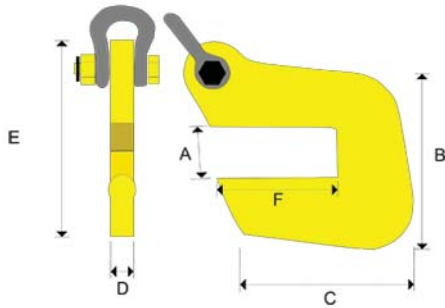

Code	WLL Tonnes	Dimensions in mm						Weight kg
		A	B	C	D	E	F	
PLH3.2T	4.5/Pair	55	208	205	25	240	140	8.3
PLH7.5T	7.5/Pair	50	208	205	36	240	145	12.5
PLH16T	16/Pair	62	208	205	50	240	145	19.5

PIPE LIFTING "C" HOOK

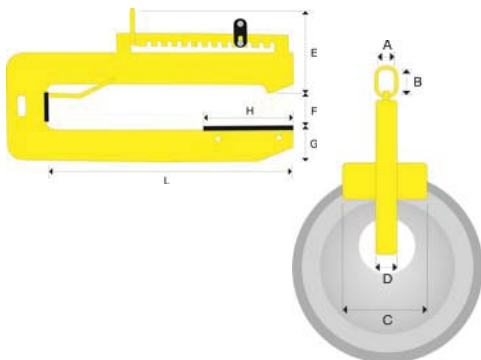

- Multi position head link allows for level adjustment for different pipe sizes
- Adjustable link stopper for repetitive lifts
- Backing plate allows to drive the pipe into position

COMPLIES WITH AS 4991-2004

Code	WLL Tonnes	Dimensions in mm									Weight kg
		A	B	C	D	E	F	G	H	L	
PLH2T	2	85	155	360	75	440	180	190	445	1330	300

